

REV	DESCRIPTION	DATE
-----	-------------	------

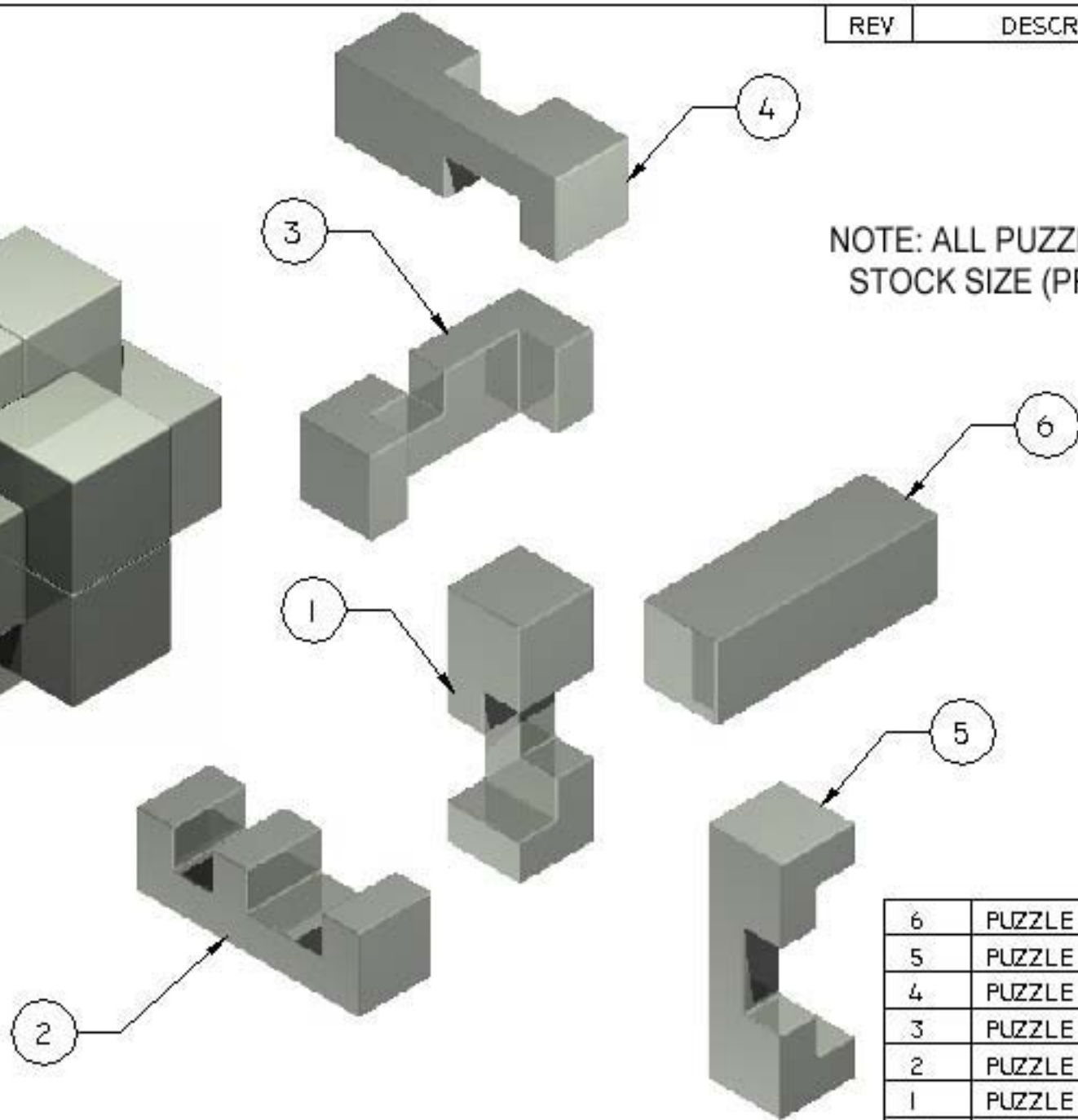
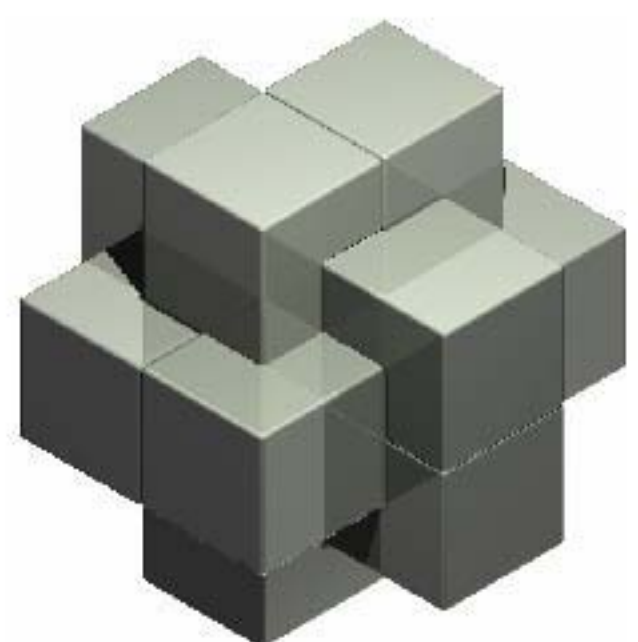

NOTE: ALL PUZZLE PIECES ARE STOCK SIZE (PROFILE ONLY)

6	PUZZLE PIECE 6	1
5	PUZZLE PIECE 5	1
4	PUZZLE PIECE 4	1
3	PUZZLE PIECE 3	1
2	PUZZLE PIECE 2	1
1	PUZZLE PIECE 1	1
No.	DESCRIPTION	QTY.

**SKILLS
COMPÉTENCES
CANADA**
SASKATCHEWAN
PRECISION MACHINING NATIONAL COMPETITION

TOLERANCES:
EXCEPT AS NOTED
.XX = ±.01
.XXX = ±.002
.XXXX = ±.0005
ANGLES = ±0°30'

HEAT TREATMENT:
NONE
MATERIAL:
6061 AL.
FINISH:
NONE

TITLE:
ASSEMBLY
DRAWN BY:
C.L.
CHECKED BY:
W.P., P. B., & P.A.R.

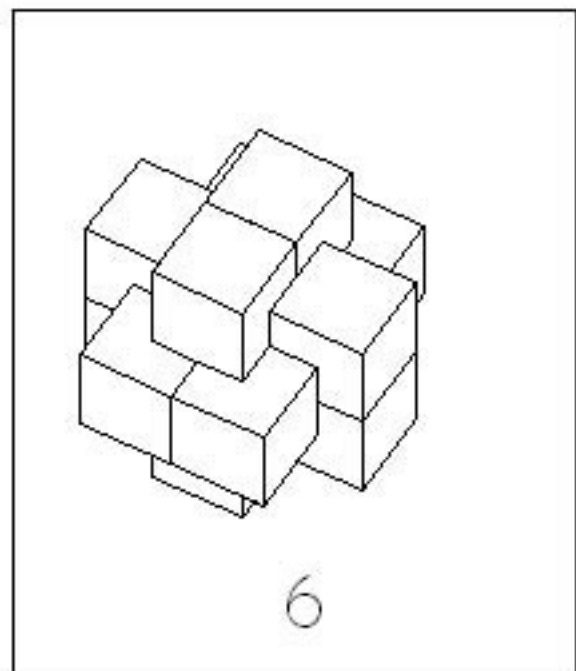
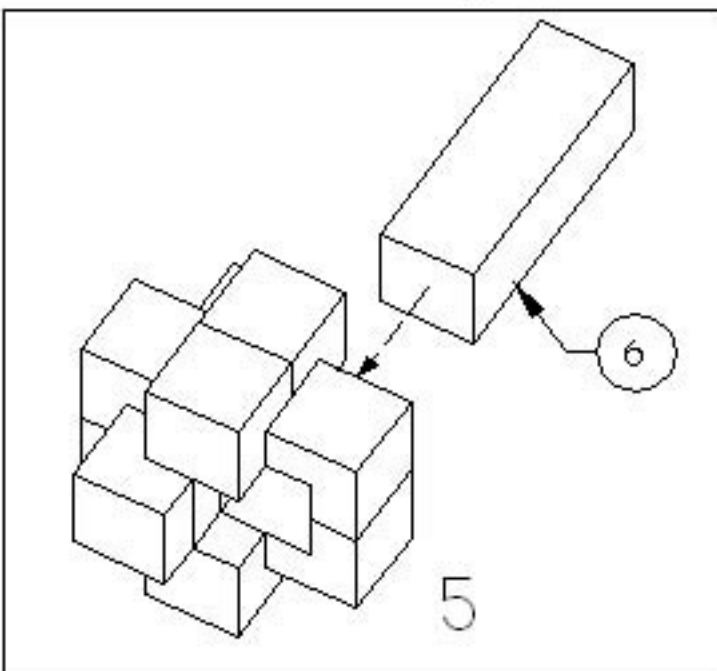
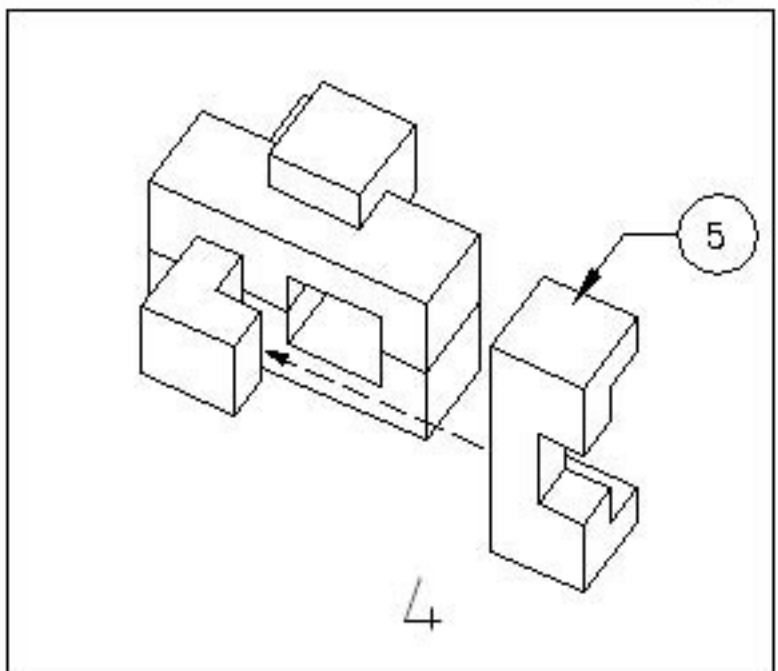
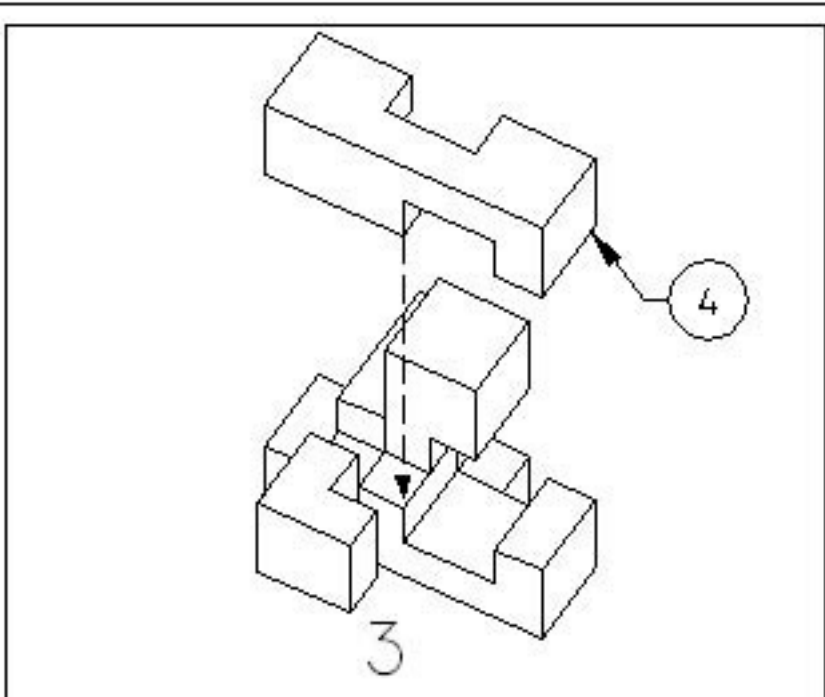
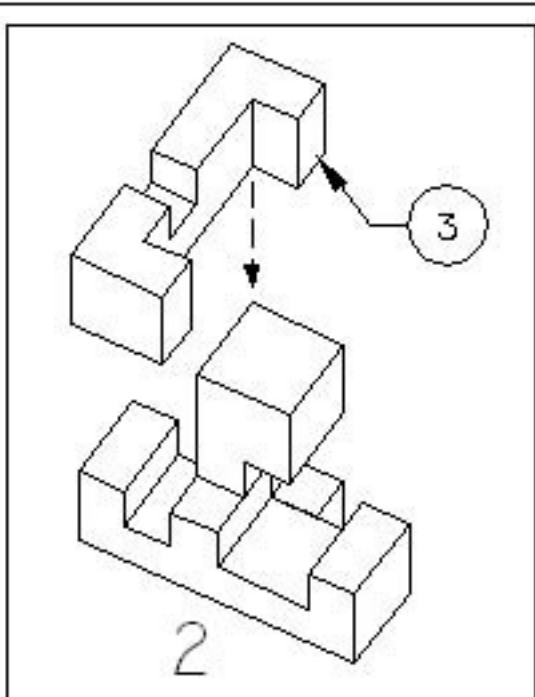
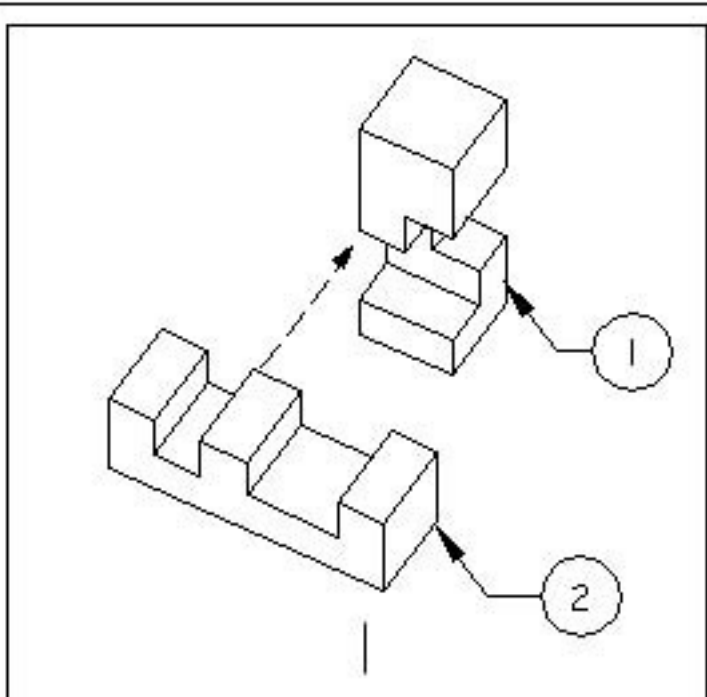

REV:
1
DATE:
MAR 2, 2007
SCALE:
N.T.S.

PART NUMBER:
PZI001
SIZE:
A
SHEET NO.
1 OF 8

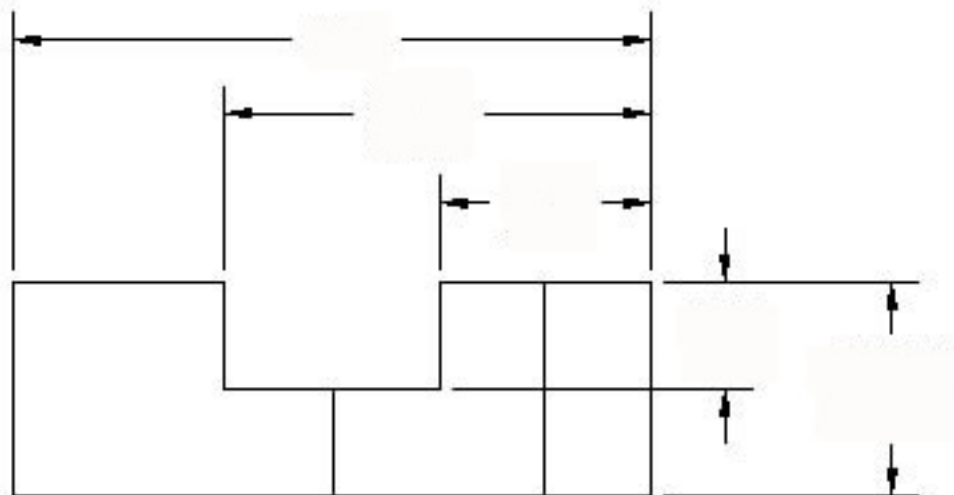
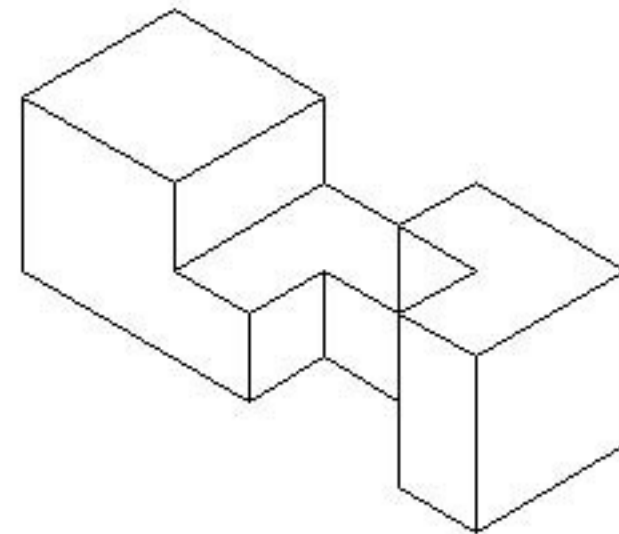
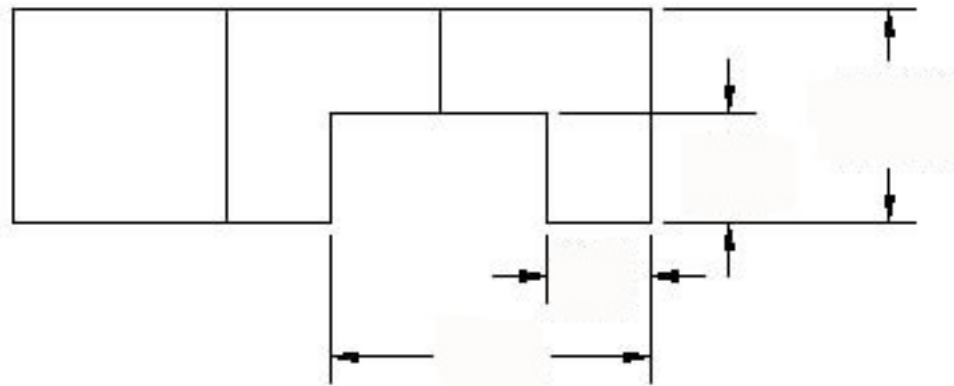

REV	DESCRIPTION	DATE
-----	-------------	------



 SKILLS COMPÉTENCES CANADA <small>SASKATCHEWAN</small> PRECISION MACHINING NATIONAL COMPETITION	TOLERANCES EXCEPT AS NOTED .XX = ±.01 .XXX = ±.002 .XXXX = ±.0005 ANGLES = ±0°30'	HEAT TREATMENT: NONE MATERIAL: 6061 AL. FINISH: NONE	TITLE: PUZZLE PIECE I DRAWN BY: C. L. CHECKED BY: W.P., P. B., & P.A.R.	REQ: 1 DATE: MAR 2, 2007 SCALE: 1:1	PART NUMBER: PZI003 SIZE: 	SHEET NO. 30F8
--	--	--	---	---	--	--------------------------

REV	DESCRIPTION	DATE
-----	-------------	------

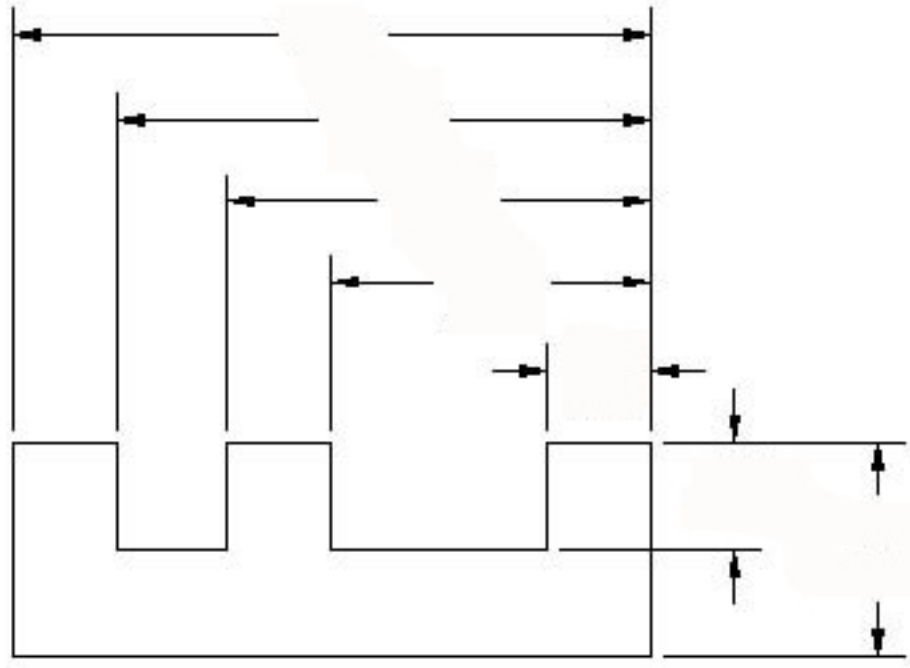
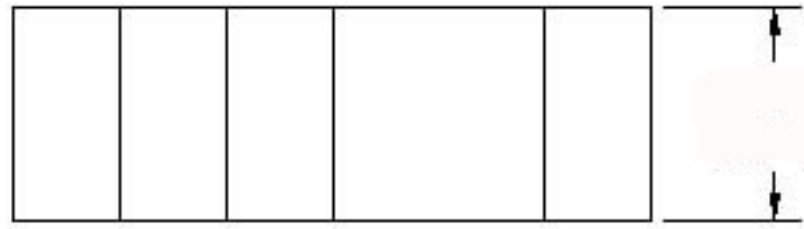
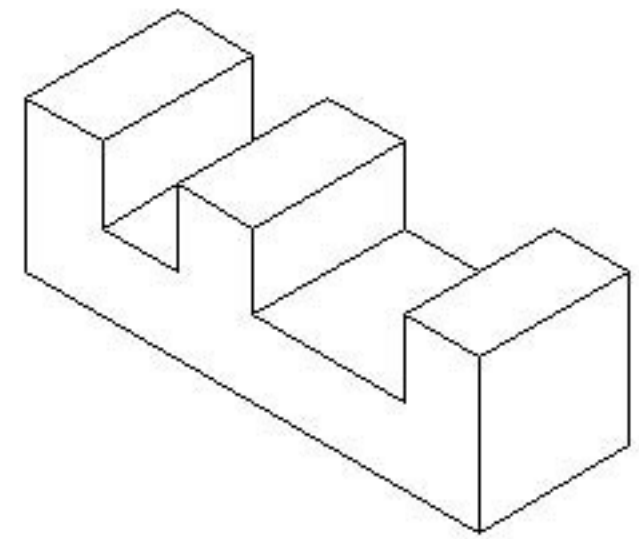

**SKILLS
COMPÉTENCES
CANADA**
SASKATCHEWAN

PRECISION MACHINING NATIONAL COMPETITION

TOLERANCES
EXCEPT AS NOTED

.XX = ±.01
.XXX = ±.002
.XXXX = ±.0005
ANGLES = ±0°30'

HEAT TREATMENT:
NONE

MATERIAL:
6061 AL.

FINISH:
NONE

TITLE: **PUZZLE PIECE 2**

DRAWN BY:
C.L.

CHECKED BY:
W.P., P. B., & P.A.R.

REQ:
1

DATE:
MAR 2, 2007

SCALE:
1:1

PART NUMBER:
PZI004

SIZE: **A**

SHEET NO.: **40F8**

REV	DESCRIPTION	DATE
-----	-------------	------

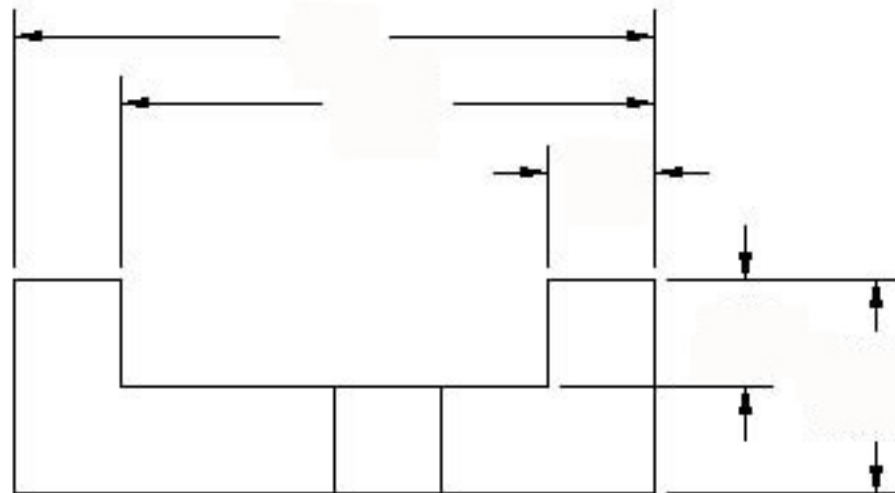
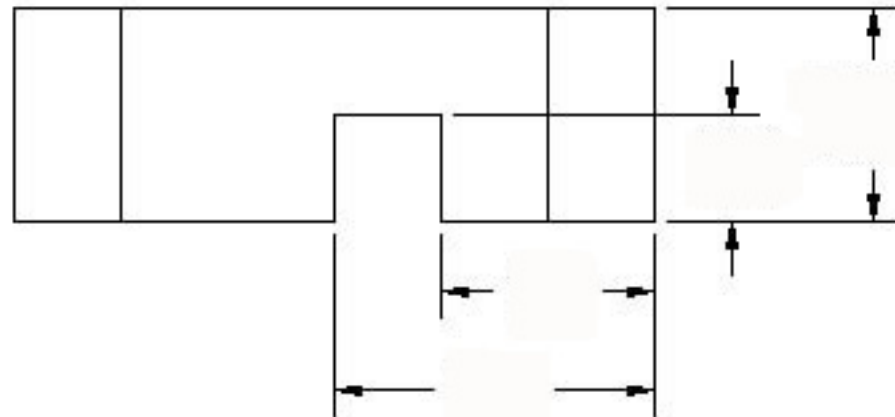
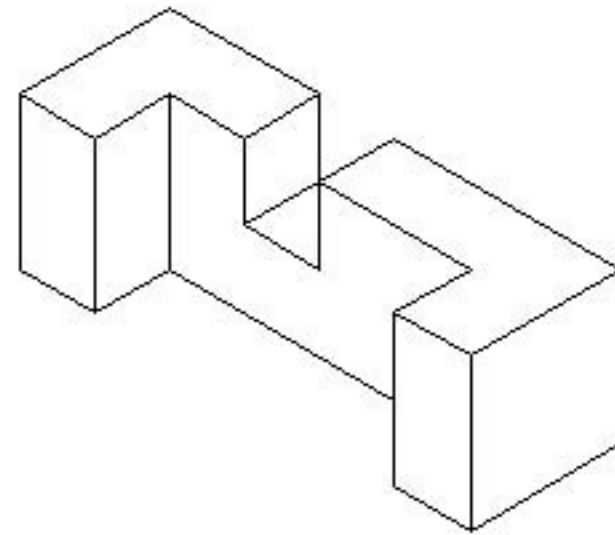

TOLERANCES
EXCEPT AS NOTED

.XX ± .01
.XXX ± .002
.XXXX ± .0005
ANGLES ±0°30'

HEAT TREATMENT:
NONE

MATERIAL:
6061 AL.

FINISH:
NONE

TITLE: PUZZLE PIECE 3

REQ: 1

DRAWN BY: C.L.

CHECKED BY: W.P., P. B., & P.A.R.

DATE: MAR 2, 2007

SCALE: 1:1

PART NUMBER: PZI005

SIZE: A

SHEET NO. 50F8

REV	DESCRIPTION	DATE
-----	-------------	------

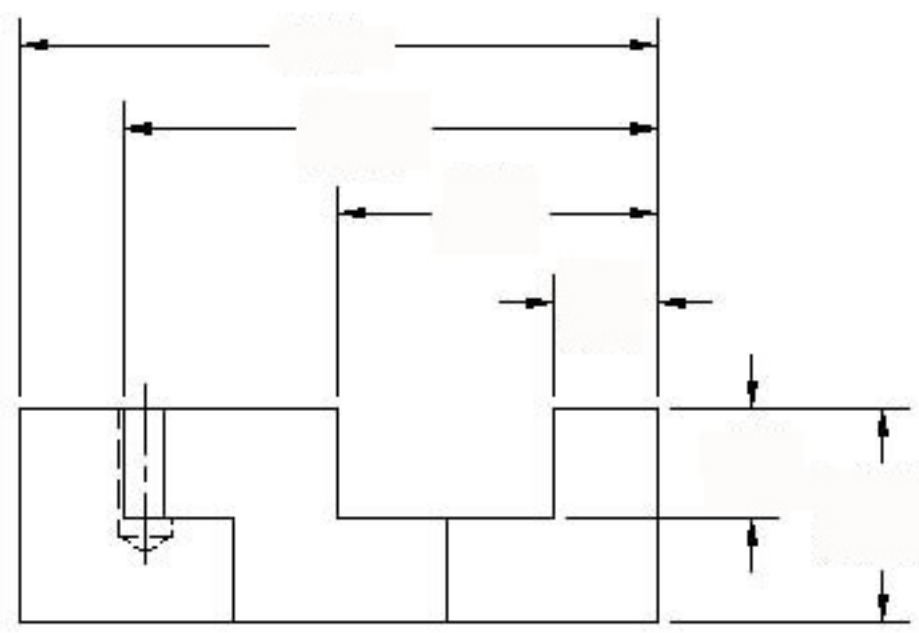
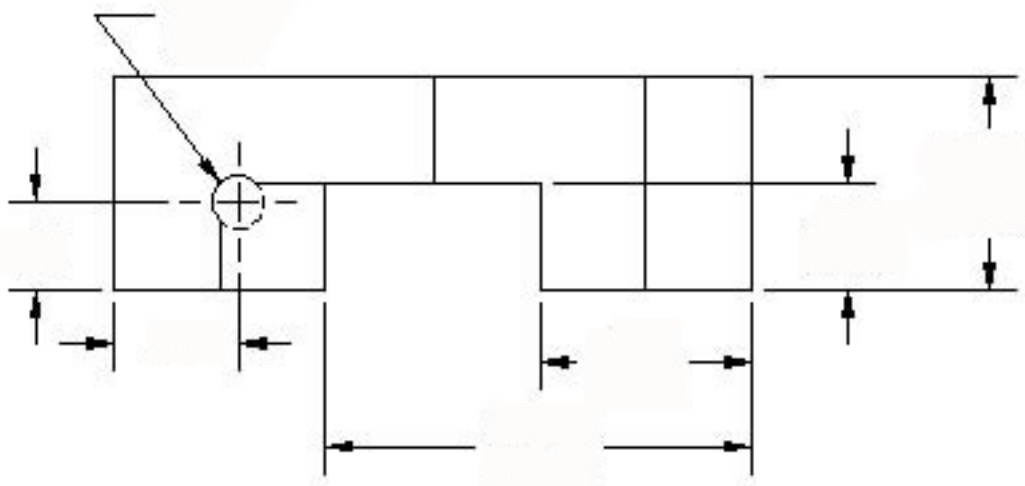
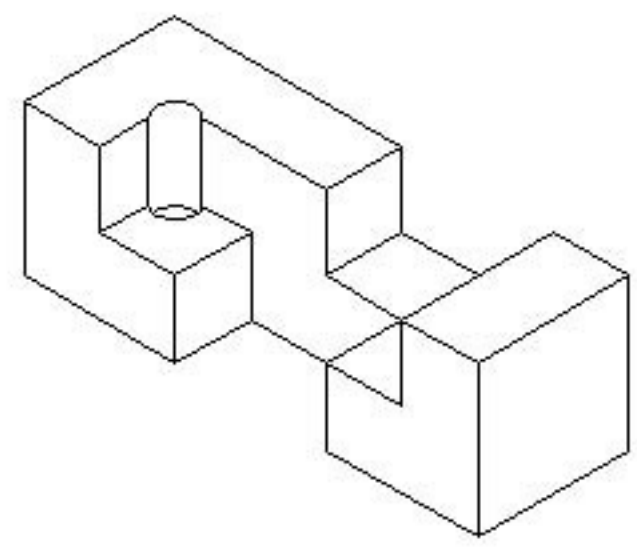

 SKILLS COMPÉTENCES CANADA <small>SASKATCHEWAN</small> PRECISION MACHINING NATIONAL COMPETITION	TOLERANCES EXCEPT AS NOTED	HEAT TREATMENT: NONE	TITLE: PUZZLE PIECE 4	REV: 1	PART NUMBER: PZI006
	.XX ± .01	MATERIAL: 6061 AL.	DRAWN BY: C.L.	DATE: MAR 2, 2007	SIZE: A
	.XXX ± .002	FINISH: NONE	CHECKED BY: W.P., P. B, & P.A.R.	SCALE: 1:1	SHEET NO. 60F8
	.XXX ± .0005				
	ANGLES ±40°30'				

REV	DESCRIPTION	DATE
-----	-------------	------

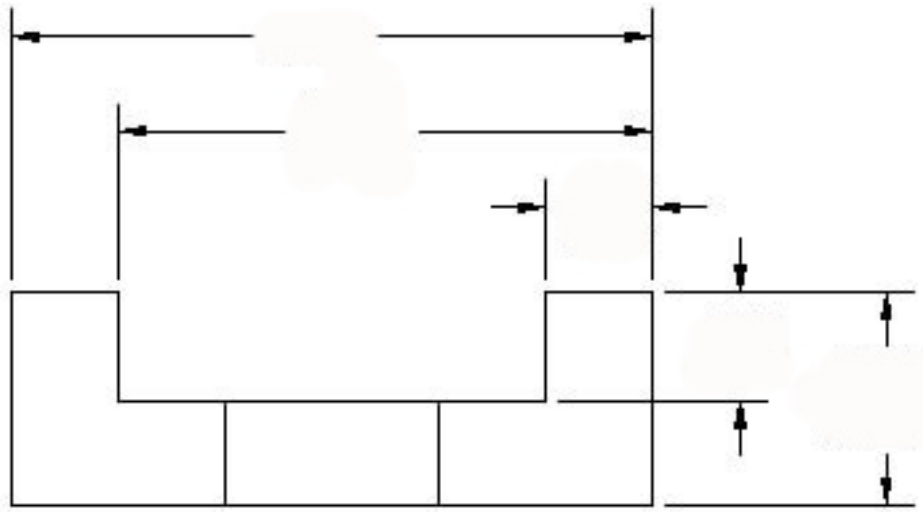
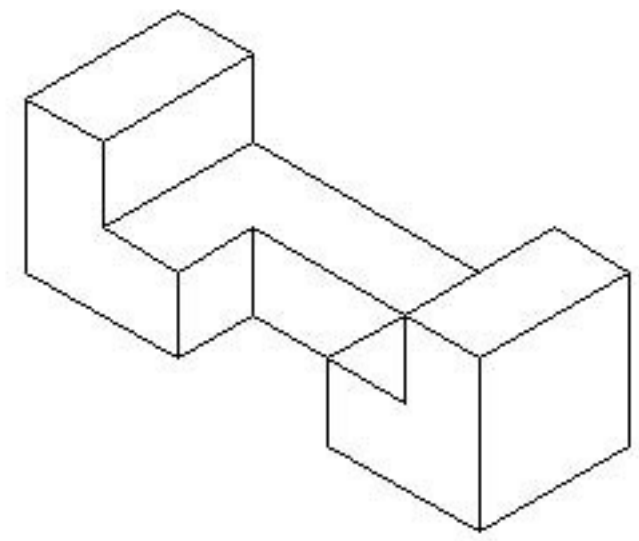
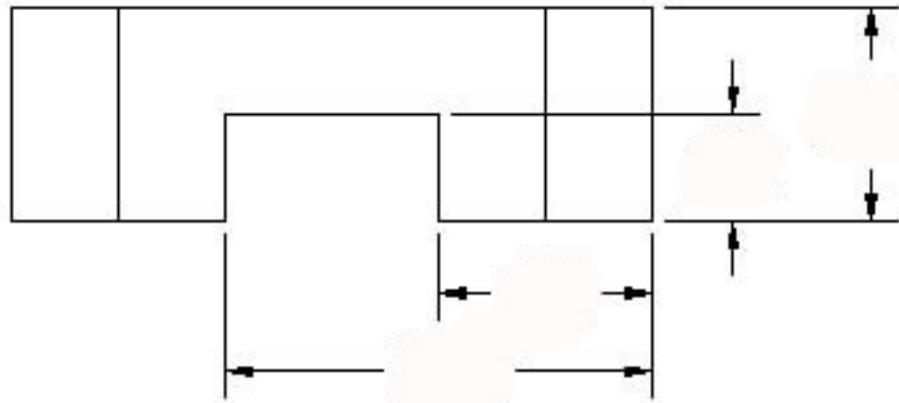

 SKILLS COMPÉTENCES CANADA SASKATCHEWAN PRECISION MACHINING NATIONAL COMPETITION	TOLERANCES EXCEPT AS NOTED	HEAT TREATMENT: NONE	TITLE: PUZZLE PIECE 5	REV: 1	PART NUMBER: PZ1007
	.XX ± .01 .XXX ± .002 .XXXX ± .0005 ANGLES ±0°30'	MATERIAL: 6061 AL.	FINISH: NONE	DRAWN BY: C.L.	DATE: MAR 2, 2007
			CHECKED BY: W.P., P. B, & P.A.R.		SIZE: A SHEET NO.: 7 OF 8

REV	DESCRIPTION	DATE
-----	-------------	------

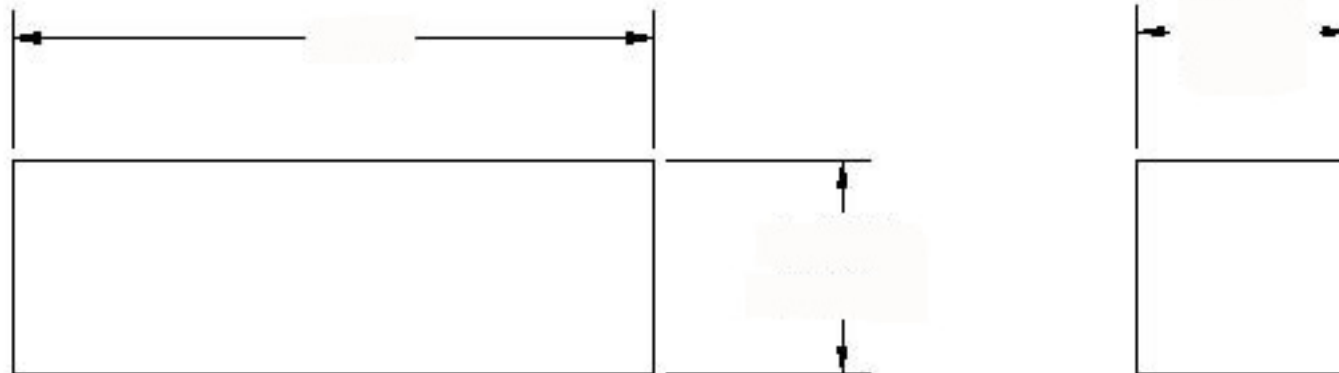
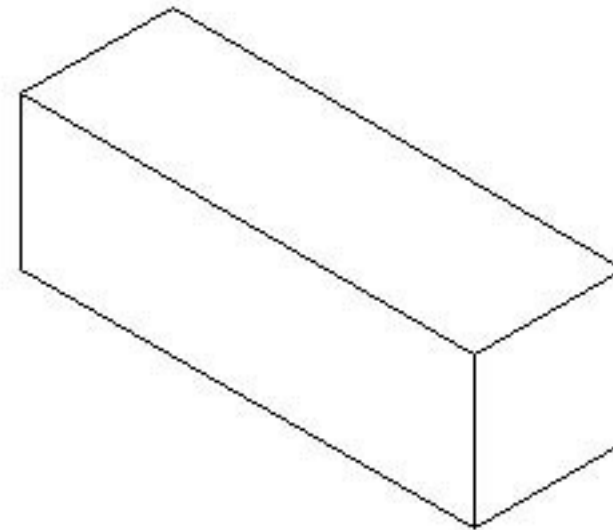

 SKILLS COMPÉTENCES CANADA <small>SASKATCHEWAN</small> PRECISION MACHINING NATIONAL COMPETITION	TOLERANCES EXCEPT AS NOTED .XX ±.01 .XXX ±.002 .XXXX ±.0005 ANGLES ±0°30'	HEAT TREATMENT: NONE	TITLE: PUZZLE PIECE 6	REV: 1	PART NUMBER: PZI008
		MATERIAL: 6061 AL.	DRAWN BY: C.L.	DATE: MAR 2, 2007	SIZE: A
		FINISH: NONE	CHECKED BY: W.P., P. B, & P.A.R.	SCALE: 1:1	